

# Metal Filing

Kimball® Office



# Everything you need in one place.

LF™ Series pages 3-4 | Fundamental® pages 5-6 | Bloxx® pages 7-8



Storage: Workers want more of it. Designers want it to **blend** with the environment. And Facility Managers want it to be **rock solid** and **secure**. Kimball Office holds the answer with **three** metal filing and storage solutions that present **more choices**.

- LF Series files are engineered and built for long-term durability.
- Fundamental files meet ADA guidelines and offer a range of aesthetic options at an exceptional value.
- Bloxx files can be configured and customized to fit everyone's needs.
- All come in a full range of paint finishes that coordinate with laminate and fabric colors across product lines. And all are as strong, hardworking and reliable as the company who stands behind them.



# LF™ Series

Built for the long haul. LF Series lateral files are quality-constructed for a **lifetime** of heavy-duty use. The reinforced steel frame and patented dual interlock system allow files to be moved **fully loaded**. Available in two-high to five-high units with finished tops, LF Series files can be used in file banks, for space division and as freestanding units to create storage islands. Additionally, most units are available within 10 days through the **PDQ quick-ship** program.

- Coordinating storage wardrobes, cabinets and overfiles support individual needs; and various height bases, file tops and paper management accessories accommodate almost any application.
- The integral Full pull matches Kimball Office's Footprint® metal undersurface storage pedestals, with universal looks to complement any office setting.
- The fully extendable drawers feature silencing bumpers for quiet operation.
- Coach seams add rigidity, presenting a clean exterior with no exposed welds.
- Four leveling glides adjust from inside the cabinet, simplifying installation and preventing accidental tipping.
- The five-high file's tightly engineered construction allows five drawers of filing in under 61 inches — you can see into each drawer.





Specify two 6" half-height drawers in place of the standard 12" drawer for space-efficient media storage.



Files can be moved while fully loaded, saving time and preventing the risk of misplaced documents.



Use the available lift door with fixed shelf in the top position of the 5-high lateral file to stand binders for quick reference.



Product specifications: LF Series files. Finish: Smoke, Full pull. Two, three and four drawer lateral files, and five drawer lateral file with lift door are shown. Detail photos finishes: Antique White and Sandstone.

# Fundamental<sup>®</sup>

Added value. Fundamental files are **simple** and **affordable**. They offer ADA-compliant features, a variety of sizes, and a range of pull choices and finish options to **fit any work setting** efficiently, aesthetically and economically. In addition, most files can be shipped within 10 days through the **PDQ** program.

- A five-drawer file with seated-access locks and easy-to-open pulls addresses ADA guidelines.
- Satisfy individual preferences with convenient and coordinating options — storage wardrobes, cabinets, overfiles, posting shelf units, file tops and paper management accessories.
- The available lift door with fixed shelf in the top of a 5-high lateral file holds standing binders, allowing at-a-glance identification of contents.
- Coach seams contribute to a rigid case and provide a clean look with no exposed welds.





A choice of pulls — Arc (shown), Rail and Extended — in a variety of finishes provides a visually compatible look throughout the workplace.



For seated access, the ADA-compliant 5-high lateral file has its lock at mid-height, above the third drawer. The easy-to-grasp Rail (shown) and Arc pull choices make opening and closing drawers effortless.



A posting shelf above the third drawer on the five-high file slides out — via a magnetic spring latch — to provide an extra worksurface.



Product specifications: Fundamental files; Finish: Taupe Metallic, Arc pull in Platinum Metallic; Worksurface: Caramel Maple; Three drawer, Storage cabinet, Five drawer/ADA compliant and Four drawer with Overfile are shown. Detail photos finish: Antique White.

# Bloxx®

Stacked with choices. Bloxx file and storage components offer exceptional flexibility and function. “Design Your Own” files provide custom solutions. Preconfigured “Easy Order” units accommodate the most popular combinations. Stackable, reversible and individually locking, Bloxx modules configure and reconfigure to suit virtually any requirement.

- For specification versatility, components come in three widths: 30", 36" and 42", two depths: 18" and 20", and stack two, three, four, five and six high. Components can be ordered fully assembled or as modules.
- Four interchangeable modules address custom filing and storage needs: lift door with roll-out shelf, lift door with fixed shelf, drawer, and two half-height drawers.
- Three front-to-back file rows in 20" deep, 42" wide drawers optimize filing capacity in all configurations. You gain 12½ inches more filing space than side-to-side filing and six inches more than an 18" deep drawer.
- Modules can be put together in opposite directions for shared workstations and open plan space division.
- All Bloxx components are available in wear-resistant paint finishes that match laminate and fabric colors across all Kimball Office product lines, for a cohesive look throughout your facility.





With the Design Your Own File program, any combination of four Bloxx module types can be configured in almost any combination to meet custom requirements.



Easy Order files feature the most popular configurations of the same modules and are shipped fully assembled.



Individual lock rod assemblies allow independent locking for increased safekeeping in shared workstations. In addition, security septums are available for placement between reversed modules.



## LF Series



Full pull

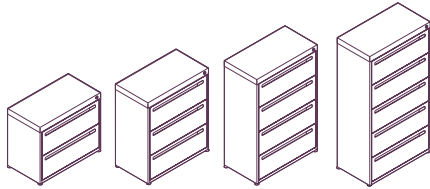

Two, Three, Four or Five Drawer

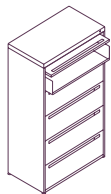

Five Drawer with Lift Door

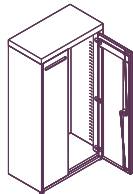

Storage Cabinets

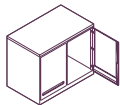

Overfiles

## Fundamental



Arc pull



Rail pull



Extended pull

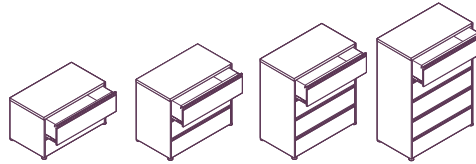

Two, Three, Four or Five Drawer



Five Drawer with Lift Door



Five Drawer with Posting Shelf

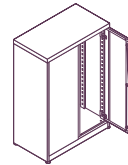

Storage Cabinets

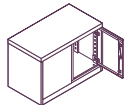

Overfiles

## All Kimball Office Metal Files have these great features . . .

### Performance and design

- Standard side-to-side file bars and optional front-to-back file bars address filing preferences and provide maximum storage volume.
- Drawers accommodate letter, legal and A4 filing.
- Overfiles may be used independently or in addition to appropriate file widths or storage cabinets.
- Shelves and wardrobe kits may be ordered for overfiles and storage cabinets to satisfy individual requirements.
- Label holders for quick identification of contents are standard.
- All Kimball Office standard paint finishes are available to ensure a cohesive look throughout the work environment.
- Knockouts are standard for ganging side-by-side.
- Four leveling glides, accessible from inside the cabinet, offer height adjustment for uneven surfaces.

## Bloxx “Easy Order”



Extended pull

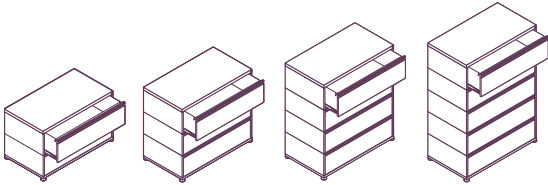

Two, Three, Four or Five Drawer

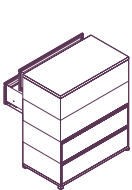

Four Drawer with Two Reverse A Modules



Five Drawer with Lift Door and Fixed Shelf



Five Drawer with Lift Door and Roll-out Shelf

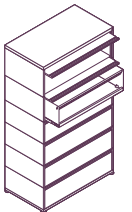

Six Drawer with Lift Door and Roll-out Shelf and Lift Door with Fixed Shelf

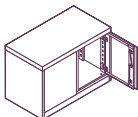

Overfiles

## Bloxx “Design Your Own”

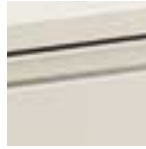

Extended pull

Top includes one lock and is finished so the file can be used as a stand alone unit.

C Module features a lift door with a fixed shelf.

B Module includes a lift door with roll-out shelf.

D Module offers two 6" half-height roll-out drawers with fixed fronts.

Security Septum can be placed in between reversed modules for optimum security.

Module A is a standard roll-out drawer with fixed front.

Heavy-duty Base available as an option, allows files to be moved fully loaded.

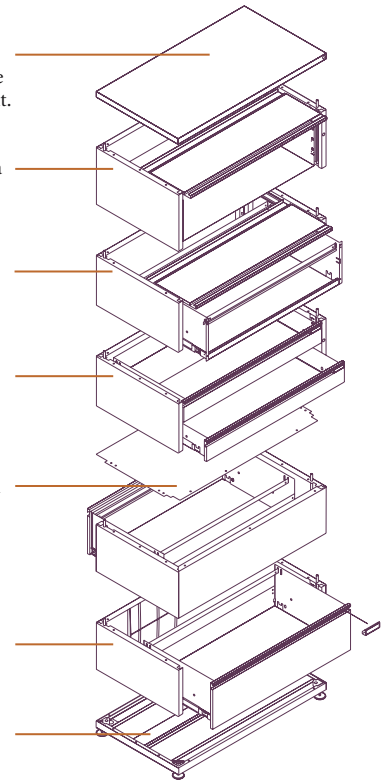

## Safety and security

- Full-extension drawer slides with steel ball bearings and silencing bumpers yield more filing space and provide smooth and quiet operation.
- A built-in anti-rebound catch prevents drawers from accidentally rolling open.
- Locks come standard with key-random or key-specific options.

## Strength and durability

- Heavy-gauge steel construction with coach seams provides a stronger file with a clean appearance.
- Counterweights are available for freestanding units.\*
- All Kimball Office metal files exceed BIFMA standards.

\*LF Series and Fundamental Files may be ganged, eliminating the need for counterweights.

# Kimball® Office. A place that works for you.

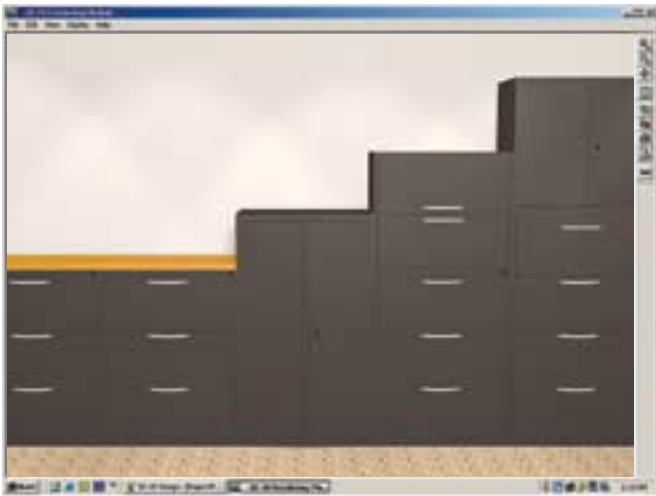

To view all the options and finishes available on Metal Filing, ask your Kimball Office representative to render it in **e-magine**, our planning, specification and visualization software.

[www.kimballoffice.com](http://www.kimballoffice.com)

A Unit of Kimball International 1600 Royal Street Jasper, Indiana 47549 800.482.1818

Due to the limitations of the printing process, printed colors may vary from actual finish samples.  
Product details and other data are subject to change without notice.  
Your Customer Care Team will be happy to answer any questions you may have.

Cover product specifications: Bloxx Design Your Own Files; Finishes: Taupe Metallic and Cement, Extended pull;  
Worksurfaces: Caramel Maple, Softened edge. Two and three-module configurations with bases are shown. Seating: Arpeggio.